



**Temporary Heating
Equipment Since 1981**

ENGINEERING GUIDE

A guide to the selection of temporary heaters
and heating systems



heat
wagon

A large, faded version of the Heat Wagon logo, including the words "heat" and "wagon" and the stylized flag icon, positioned on the right side of the page.

Rev. 6-22

**(219) 464-8818 • Fax (219)462-7985
342 N. Co. Rd. 400 E. • Valparaiso, IN 46383 • www.heatwagon.com**

TABLE OF CONTENTS

INTRODUCTION2

BASICS OF TEMPORARY HEATING3

RECIRCULATING vs PRESSURIZATION ...3

BASIC EQUIPMENT TYPES4

HEAT TRANSFER6

CONDUCTION, CONVECTION, RADIATION.. 6

HEAT LOSS/GAIN6

FUEL FACTS7

HOSE/PIPING8

ELECTRIC POWER8

BY-PRODUCTS8

COMMON PROBLEMS9

ON SITE HAZARDS9

JOB SIZING9

FUEL AND POWER CONSUMPTION9

CHARTS & TABLES10-26

REGULATORS27

DRAGON WAGON28

INTRODUCTION

The purpose of the Heat Wagon Engineering Guide is to provide information and instruction in the selection of temporary heat equipment and systems for construction sites, primarily in the early and middle stages of building.

There is no known text on this subject, although there are many on permanent heating systems. Some of the material from the Guide is drawn from such texts as well as from fuel gas codes, gas and propane association publications, and electrical engineering manuals.

This guide is intended for use by individuals who sell temporary heating systems and those who provide technical support.

While the purpose of the Heat Wagon Engineering Guide is to be helpful in the process of estimating temporary heating requirements, determining appropriate systems to use, fuel and electrical costs, and heater placement, Heat Wagon does not assume the ultimate responsibility for the overall effectiveness of individual projects. Actual jobsite conditions may require adjustments not anticipated in this general guide.

In all events, federal, state and local codes take precedence over recommendations in this guide.

BASICS OF TEMPORARY HEATING

In construction, temporary heating is commonly used to allow construction activities to continue throughout the winter season. On-going construction, worker comfort, safety, protection of structural components, concrete curing, and other factors during cold weather can make temporary heating a significant contributor to the profitability of winter work.

Temporary heating is used because permanent heating systems are not yet installed or activated. Little attention has been paid to the necessities of temporary heating design even though there are many sources of information on permanent heat design.

Insulating values of all structural components are taken into account. Structures that house people and equipment may require more heating and will be designed differently than buildings that serve the sole purpose of warehousing. System designs will account for outdoor design temperature and desired indoor temperatures, wind forces, land mass and other factors. It is assumed that openings, such as doors and windows, will be installed and closed when making these calculations.

From time to time, contractors or building owners will attempt to use permanent heating designs to determine temporary heat requirements. This is a poor way to calculate heat losses during the construction cycle. Designs for permanent systems do not adequately address heat loss issues such as infiltration of cold air in the early and middle stages of construction. Cold air infiltration is easily the greatest source of heat loss in a building under construction. Even a fully completed building, ready for occupation, suffers from infiltration of cold air.

Another great heat loss is through the roof or ceilings due to conduction and radiation.

Controlling these two main sources of heat loss, by proper system sizing and selection, will also address two other concerns for those contractors who are going to use temporary heat: the accumulation of moisture and the air quality within the building.

RECIRCULATING vs. PRESSURIZATION

There are two basic methods of employing temporary heat. One method is called recirculation and the other is known as pressurization or air exchange.

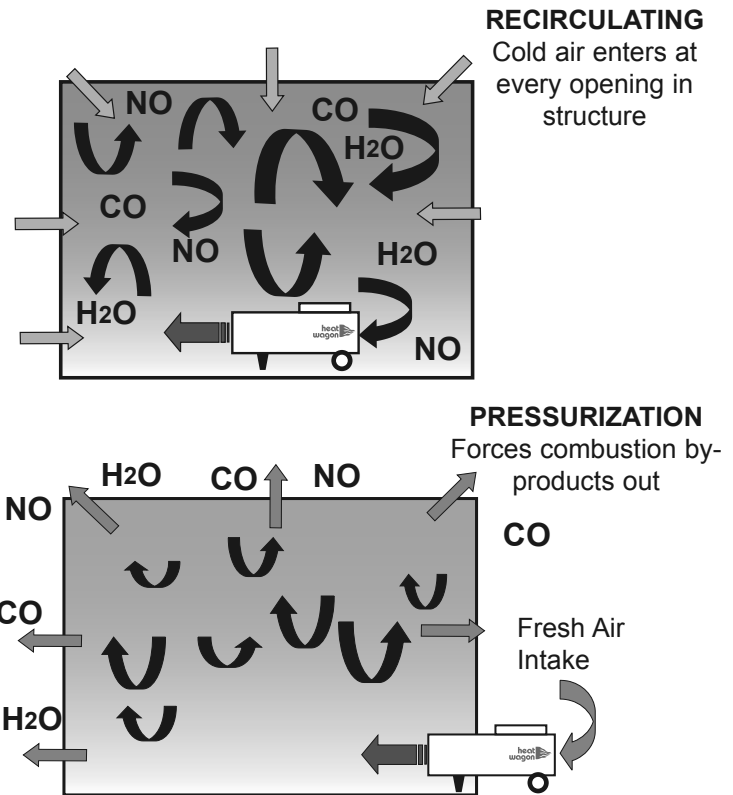

Recirculation has been used for many years and is derived from the use of relatively small portable heaters sometimes known as torpedo or salamander heaters. The largest of these heaters in common use is 600,000 BTU, with air flow, in cubic feet per minute (CFM) up to 3,000. Historically, the majority of these types of heaters have been fueled by kerosene or fuel oil.

Recirculating, or portable heaters, are placed inside a building and are fired by fuel and air from within the building. While there have been improvements in the design of portable heaters and expanded fuel options, the operation remains the same, that is, burning or consuming of air (oxygen) contained inside the building.

There are problems associated with this method. The predominant problems are: depletion of oxygen during the burning process and accumulation of by-products of combustion back into the heated space which are then recycled through the heater. By-products include carbon monoxide, carbon dioxide, and water vapor which accumulate, while oxygen is depleted.

It is always recommended that outside air be introduced to the interior spaces to prevent the uncomfortable and sometimes dangerous accumulation of these by-products when using recirculating heaters.

In addition to these drawbacks, combustion inside the building with interior air creates a partial vacuum, encouraging infiltration of cold air. As said before, infiltration of cold air is a principal cause of heat loss. Heated air inside the building tends to be spotty and uneven under these conditions and potential code violations.

Recirculating heaters also obstruct work in progress while providing uneven heat distribution. Hoses and tanks are also obstructions.

The other method of employing temporary heat is referred to as the air exchange or the pressurization method. This method addresses all of the problems associated with the recirculation method.

The pressurization type heaters range widely in BTU capacity. They are usually fueled by natural gas, vapor propane, liquid propane, or fuel oil. They all share the characteristic of having high temperature rises, i.e., the difference between input air and output air, high air movement, expressed in cubic feet per minute (CFM), and high static pressure.

High temperature rise with high CFM and high static pressure permit these types of heaters to use air from outside the building to pressurize the building. The net effect of this pressurized air flow is to spread heated air evenly throughout a building.

Several important things begin to happen as this heated air spreads. The foremost is the reversal of infiltration of cooler air. Where cold air has been entering, it is forced back out of the building. The by-products of combustion, carbon monoxide and water vapor are expelled as well. Heated air tends to be more evenly spread throughout the building.

Naturally, efforts to tighten the building enclosure must be made in order to achieve maximum results from pressurization. It is the contractor's responsibility to continually tighten the enclosure.

Regardless of the method selected, pressurizing or recirculating, a consideration of the type of equipment used by either method is needed. The equipment should be portable and compact. Heaters should use readily available fuel and power. Operational safety and environmental safety are priorities. Heaters should be designed and engineered to meet high standards. **It is to be expected that equipment has been tested and approved by independent laboratories for both manufacturing standards and safe operation.** There must be rational calcu-

lations of estimated fuel expenses, electric costs, set up and maintenance costs, supervisory costs, and so forth.

BASIC EQUIPMENT TYPES

There are four basic heater types used in temporary heating. They are direct fired, indirect fired, electric and hydronic.

Direct fired are economical and practical for most temporary heat applications, as long as they have been selected, placed, and applied correctly. Direct fired heaters function by drawing cooler air into the heater by means of a fan. The cool air then passes over exposed flame which increases the air temperature. As the heated air passes through the heater the discharge temperature is controlled by heater components. This type of heater is nominally 100% fuel efficient. If 100,000 BTU is introduced to the heater, then 100,000 BTU is the approximate output. As mentioned earlier, a small amount of this combustion process produces by-products which are manageable and safe. This is true when used as pressurizing heaters.

Direct fired heaters can be divided into 2 different categories. The open flame, "torpedo" style is very common (see figure A) page 5. They may be controlled with an off/on or high/low remote thermostat. These units may be certified to be operated with ducting. However, the ducting needs to be temperature rated for the temperature rise of the heater. The cost of this type of heater is the least expensive of all temporary heating systems.

The second type of direct fired heater is the "make-up" air unit. The principle function of this unit is to introduce heated outside air into the structure and distribute the air in a controlled fashion to replace the air that is being exhausted. A popular design for the "make-up" air unit is the "draw-through" design (see figure B) page 5. The fan pulls the outside air across the burner, whereas, in the "torpedo" style, the outside air is pushed or "blown-through" across the burner. It should be noted that "blown-through" make-up air units are also manufactured for temporary heating.

In recent years, temporary heating quotation proposals have contained the statement: . . .No open flame salamander type heaters are permitted. . .Make-up air units have been used to comply with this requirement since these types of heaters are set-up outside the structure and the heated outlet air is ducted into the workspace.

Listed below are the major characteristics/differences between "torpedo" and "make-up" air heaters.

	<u>Torpedo Style</u>	<u>Make-Up Air Style</u>
Open, Exposed Flame	Yes	Typically concealed
Temperature Rise	200 to 400F	150 to 250F
Fan Type	Axial fan (one speed)	Centrifugal blower, with higher static pressure and possible variable drive for adjustable air output
Ducting	Possible	Yes, typically with longer duct length
Temperature Control	Usually high/low or on/off thermostat	May have additional control with modulating gas valve to produce variable heat output. Up to 10:1 turn down ratio.
Products of Combustion	CO, CO ₂ and H ₂ O	Identical to the Torpedo open flame

Direct Fired-Fig. A

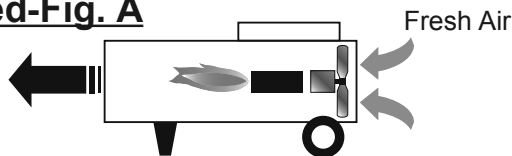

Make-Up Air-Fig. B

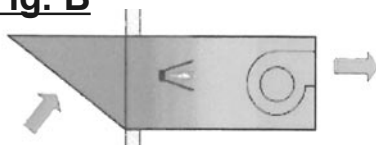

Indirect Fired-Fig. C

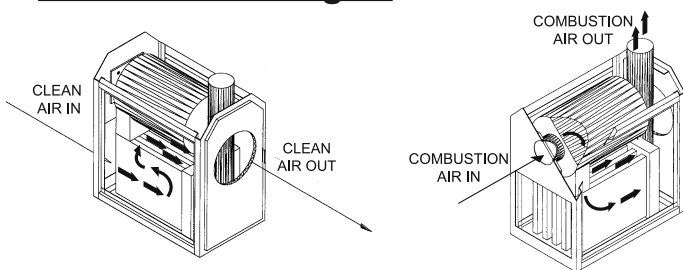

Hydronic-Fig. D

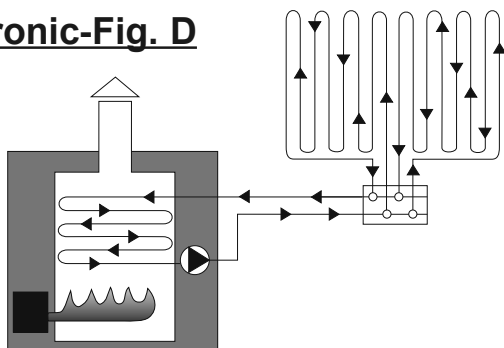

Indirect fired heaters operate differently. Cooler air is drawn into a contained burner chamber where the fuel is fired and the combustion process begins. The heater also draws cool air over a separate chamber called a heat exchanger. The two streams of air: combustion air and heat exchange air do not intermingle. Combustion air heats the heat exchanger air. Combustion by-products are discharged through a vent or flue along with the excess heat. **Note: Indirect fired heaters always have a chimney.** The air heated by the heat exchanger is discharged into the structure to be heated. Therefore, in a vented heater, the usable temporary heat is free of any contamination or water vapor produced in the combustion process. This heat is clean and it is dry.

Though still simple in operation and application, indirect fired heaters require more components, mostly in sheet metal parts. It is the nature of vented heaters to produce some waste heat. In the past, the best fuel efficiencies possible were in the 35% - 40% range. Today's manufacturing and design capabilities make it possible to increase efficiencies to about 80%. In short, direct fired heat is nearly 100% fuel efficient while the best available indirect fired heaters are about 80% fuel efficient. As a result, operating costs with indirect fired heaters can be somewhat greater than operating costs with direct fired heaters in the pressurization mode with outside air. However, in the recirculation mode, fuel savings up to 50% can be realized with indirect heaters.

Indirect fired heaters are used in cases where air quality is of utmost importance, such as in hospitals or schools. These heaters are also used where drying is needed.

Indirect fired heaters do not add moisture to the building whether used as pressurizing or recirculating units.

Temporary heat provides for a third type of heater. **Electric** heat is used in relatively small enclosures when clean, dry heat is required. The main drawback to electric heat is the small heat capacity relative to the cost to power them. Electric heat is considered to be six or eight times more costly to operate than gas or oil-fired units.

A more recent development in temporary heating is known as **hydronic heat**. It is a hot water circulating system. This type of equipment owes its design to ground thawing equipment which heats a glycol mix and transfers heat through flexible hose to the ground. Hydronic heaters do not heat the air directly, but instead heat a water glycol mixture which is then pumped through flexible hose to heat exchangers. These heat exchangers are placed inside a building to provide warm air. The main advantage of this type of system is not the warm air provided which is somewhat limited by its design, but rather the drying effect produced by separating the combustion process from the heat transfer process, as in indirect fired heaters.

All the heaters described have their own purpose. The challenge is to determine the need, and to then balance cost, convenience, portability, and effectiveness in meeting

the primary goal of temporarily heating buildings under construction. After all, temporary heating is meant to permit construction activities to continue during the winter season, safely and profitably.

HEAT TRANSFER

Heat is normally measured in British Thermal Units, or BTU. One BTU is the amount of heat required to raise the temperature of one pound of water, one degree Fahrenheit in a controlled setting.

For convenience, heaters are rated by BTU input, regardless of the type of fuel used. Indirect fired heaters are also rated by fuel efficiency.

Understanding how heat transfer occurs inside a building allows for the best selection of methods and heaters to use. After those decisions are made, it is necessary to decide on fuel choices, power options, heater placement, hose or piping needs, and heat distribution. How heated air performs inside a building is not a particularly difficult thing to understand. Air is heated, expands, and becomes lighter. Lighter air rises. Heated air tends to layer or stratify, and it always wants to move from warm areas to colder areas. When a building is heated with warm air it is heated from the top down and from the warmer areas outward to the cooler areas of the building.

Understanding how heat moves makes it easier to take advantage of that movement. In heating higher ceilings or decks or heating higher floors, the heat is allowed to rise. If it is required that the heat move downward, fans or ductwork is used to direct the warm air to where it is wanted. Tilttable fans, used to force warm air from high ceilings back down to the normal work areas, can slash fuel costs 15-20%.

Heat moves from warm to cold. That means it is not necessary to surround a job with heaters. It is more important to place the heaters near the fuel source, available power, and within building openings such as doors and windows. With this placement, the heaters are used in the pressurization method. Long piping runs and heavy power cables are often an indicator that these principles are not being acknowledged.

CONDUCTION, CONVECTION, RADIATION

There are three forms of heat transfer: conduction, convection, and radiation. They can be defined as follows:

Conduction is the transfer of heat through a solid object (a spoon handle in a hot cup of coffee). Convection is the transfer of heat by movement of fluids or gases. A forced air heater is a convection heater.

Radiation is the transfer of heat from one object to another without warming the space in between (as the sun warms the earth).

The importance of understanding heat transfer is that in temporary heating, the most efficient heating is attained when all three types of heat transfer are put into play and heat sink is attained.

Heat sink is attained when the temperatures of the air, floor, and building framework or sidewalls are all approximately the same.

This is accomplished by pressurizing the building with forced air heaters (convection). The air temperature starts to warm the concrete slab and/or steel which warms itself (conduction) and then these warm objects throw heat back into the building (radiation). When this occurs, you have attained heat sink. At this point, a heater will drop to low fire automatically or shut off entirely until there is a temperature drop and the entire method repeats itself. A word of caution: in certain instances, it is not unusual to take a number of days to attain heat sink. In some instances, higher fuel consumption for the first few days is to be expected.

The most effective and efficient way to heat a building is through pressurization. To pressurize a building is to force more air into the building than it can hold. When this happens, warm air is forced out the crevices, joints, open windows, and doors. When calculating heat loss, remember that the largest heat loss on any structure is infiltration.

If cold air coming into a building can be reversed, temporary heating costs can be reduced by as much as fifty percent.

HEAT LOSS/GAIN

Heat loss is based on the cubic feet of the building. Square feet is of no value in calculating heat loss. Cubic feet should be determined by close inspection of the blueprints, or taking actual measurements. Walking through and around the job to get a "feel" for how the heated air will move is invaluable.

Temperature rise is the difference between anticipated outdoor temperature and desired indoor temperature. The contractor or building owner will also tell you what temperature is desired indoors. The difference is temperature rise. For example, if desired indoor temperature is 45° F and outdoor temperature is 20° F, the temperature rise is 25° F.

Now that cubic feet, outdoor temperature, indoor temperature, and temperature rise is known, heater sizing can begin.

Although there are complex programs to calculate heat loss, they heavily involve elements which have little to do with the estimates needed for temporary heat. For almost all temporary heat projects, the following formula is more than satisfactory.

1 BTU per cubic foot for every 10°F temperature rise. For example, to achieve a 25°F temperature rise, simply multiply cubic feet by 2.5.

Simple example:	180,000 cubic foot single floor building
Outdoor temperature	20° F
Indoor temperature	45° F
Temperature Rise	25° F
	$180,000 \times 2.5 = 450,000 \text{ BTU}$

Other factors may need to be taken into account, which may cause revisions, either up or down in the estimate. These factors are likely to change as construction continues. A quick reference graph to these factors is included in this guide. See Chart 6, Page 15.

For simple shell construction such as warehouses with little or no partitioning and limited to a single floor, an alternate formula will work almost equally well. That is: divide the cubic feet of the structure by 60 (60 minutes to the hour). This will show the cubic feet per minute (CFM) of air required to completely exchange the building air once per hour. This formula should be limited to single floor, open plan construction.

Example:	180,000 cubic ft
	$180,000 \div 60 = 3,000 \text{ CFM}$
	Select a heater or heaters which will provide at least 3,000 CFM.

We have described two formulas for sizing heaters, both of which are used on single floor applications. Multiple floored buildings require additional calculations but are still based on warm air rising and moving from warm areas to cool areas.

Because most movement of people, equipment and supplies occur on the first floor, it should be provided with additional heat.

For the second and third floor, provide for 50% of the BTU's used on the ground floor. It is possible that no additional heat will be required on the 3rd floor. Use fans to move heat from stairwells into upper floors. The number of such fans depends on the number of stairwells available and are placed on the landings to pull heat from the stairwells onto the floor.

For buildings taller than 5 stories, determine if the builder intends to heat all floors at the same time. Commonly, they do not, in which case, calculate only the heat loss on contiguous floors.

Floor deck heating can be done simply by allowing heat to rise to the underside of the decking. Select heaters with high temperature rise whenever possible. Air movement is less important in this application. We want the warm air to rise to the underside of the decks and to remain there.

FUEL FACTS

Fuel choices for direct fired and indirect fired heaters are natural gas, vapor propane, liquid propane and fuel oil.

Which fuel is used depends upon customer preference, availability, pressures and flows, and relative cost.

Each fuel has its advantages and disadvantages. Propane offers high pressure and flow. Natural gas offers wide variations in pressure but also offers uninterrupted availability. See Chart 7, Page 17.

At this point, we should mention that there are some applications which call for electric heat. Such applications are not usually considered temporary heat, for our purposes. Electric heaters are not commonly available with high BTU capability. Electric heat is produced by electrical resistance. The greater the resistance, the greater the BTU output. To generate a mere 205,000 BTU requires 3 phase 480 volt 70 amp service. Electric heat is, by far, the most costly way to heat enclosures. The advantage is that the warm air produced, though small, is both free of contaminants and provides dry air. Electric heat is for rooms rather than buildings.

Fuel costs for propane, natural gas, and fuel oil vary widely across the country and can change rapidly. Cost per unit of measure alone should not override other issues.

Propane is an often misunderstood fuel. There is a unique relationship between tank size, outside air temperature, and vaporization rate. Propane in a tank is a liquid. Although propane suppliers vary the ratio from time to time, a "full" tank is 85% liquid and 15% vapor.

When the tank is opened and vapor is used, the liquid propane in the tank "boils" into vapor. This boiling action is caused by the outside temperature on the liquid filled or wetted part of the tank.

As outside temperature drops, boiling slows down. Tank pressure drops and less vapor is produced. Nearly the same thing happens, as propane is consumed. As fuel is consumed, the liquid propane level drops and there is less wetted area of the tank to boil into vapor.

As temperature drops, pressure drops, and the vaporization rate drops.

Chart 8, Page 17 demonstrates the rate of vaporization in various tank sizes, 250 gallons through 1,000 gallons, and manifolded at 0° F outside temperature and at 60% of liquid capacity. 60% is used to allow a comfortable margin in calculating tank requirements.

Chart 9, Page 17 demonstrates bulk tank pressures at outside temperatures from -40°F to +40°F.

HOSE AND PIPING

It is best practice to place heaters in building openings close to the fuel source and close to dependable electric power.

In order to choose the correct hose or piping for a heater three things must be known.

- Fuel Type - natural gas, vapor propane or liquid propane
- Fuel pressure at the source
- Distance to the heater

Chart 10 and 12, Page 18-20 illustrates flow rates for hose and piping at pressures from less than 1 pound per square inch (psi) through 20 psi for natural gas. The charts given do not give values for 3/4" hose; use 1" pipe as equivalent of 3/4" hose. An example of proper pipe sizing can be found on page 22.

Chart 11, Page 20 shows flow rates for liquid propane in gallons per hour, for hose and piping in diameters from 1/4" through 2". To eliminate potential problems with liquid propane called slugging, use the smallest diameter hose or piping possible, see liquid propane Chart 12, Page 20. Refer to page 22 for proper bulk tank placement. Liquid propane may not be used inside a building under any circumstances. Place and use liquid propane heaters in building openings with all hose and piping outside the building.*

*Please refer to federal, state and local codes for appropriate use of hose and piping. Some codes permit no hose to be used.

HIGH PRESSURE REGULATORS

Heater specifications include minimum and maximum inlet pressure requirement. Specifications may be in inches of water column (w.c.) or pounds per square inch (psi). 27.7 inches w.c. equals 1 psi.

When inlet gas pressure is greater than the maximum pressure called for in the specifications, a high-pressure regulator is required. For example, if the specifications reads 14 inches w.c. maximum inlet pressure and gas

pressure is 5 psi, a regulator must be added to the heater at the inlet.

Chart 13, Page 21 will guide you to the correct regulator as specified by Heat Wagon. For circumstances outside the chart parameters please call Heat Wagon Technical Support at 219.464.8818, extension 2003.

ELECTRIC POWER

All Heat Wagon heaters have recommended minimum cord size decals. Circumstances may arise where these recommendations are not suitable for a specific application. Refer to Chart 14, Page 21 for guidance. Whenever possible, place heaters as close as possible to the power source.

BY-PRODUCTS OF THE COMBUSTION PROCESS

Direct fired heater by-products of combustion are carbon dioxide, carbon monoxide, nitrous oxide, and water vapor. Of these, only carbon monoxide and water vapor are of major concern.

OSHA has established standards for carbon monoxide accumulation inside the building envelope. The standard can be found readily in the NIOSH Pocket Guide to Chemical Standards, Publication 97-140. The Pocket Guide is available at no charge from the US Government Printing Office at 866.512.1800.

The 2004 issue of the pocket guide shows the 8-hour time weighted average accumulations for carbon monoxide to be 50 ppm.

Please be aware that this standard applies not to heaters or other equipment, but rather the total accumulation of carbon monoxide in the building envelope over an 8-hour period. Heaters are probably not the cause for carbon monoxide accumulation, particularly when used in their proper mode, as pressurizing heaters. In many instances, other equipment on the job site may be producing far more carbon monoxide than the heaters. Troweling machines, generators, compressors and loaders are often found in the same workspace.

It has been said by some temporary heating suppliers that carbon monoxide should be estimated on the basis of the functionality of the heater. This is incorrect. Actual measurements of carbon monoxide accumulation should be taken over time throughout the structure, at various times in a workday. There are devices on the market for that express purpose.

Water vapor, introduced by the combustion process with direct fired heaters, is reduced or eliminated by the pressurization method. Further, for dehumidifying, air movement greatly aids the process. If water vapor becomes an issue, simply add fans to encourage air movement.

COMMON INSTALLATION AND OPERATIONAL PROBLEMS

1. Low Voltage - This is one of the most common problems and is usually the result of the supply cord having too small a wire gauge for its length. Low voltage results in the motor overheating, burnt relay contacts or a relay that will not make contact.
2. Gas Supply Line Too Small
3. Insufficient Vaporization At Supply - Normally caused by improperly sized propane tank.
4. Improper Gas Supply Pressure - Usually a result of supply pressure being too high or too low because of improper or lack of regulation. Refer to the heater's instruction plate for the maximum and minimum inlet pressure rating.
5. Dirty Gas Supply (Dirt in hose or supply pipe) - Dirty gas can cause strainers to plug or form a buildup in the burner orifice.
6. Lack Of Preventative Maintenance - Heaters must be cleaned as required, especially when used in a dirty environment.

ON SITE HAZARDS

1. Shorting Or Jumping Out Of Defective Components - This is a very common problem which saves short term expense at the risk of large future costs. Any heaters found in this condition should be removed immediately.
2. Improper Enclosure - When heaters are installed partially to the outside for fresh air intake, strict adherence must be made to the minimum clearance to combustibles given on the instruction plate. Wood framing around a heater poses a potential hazard.
3. Supplying Liquid Propane To A Vapor Heater - This problem has occurred from time to time. To minimize the damage, shut off the gas supply and let the heaters run until all of the liquid in the lines has been burnt.
4. Improper Or No First Stage Regulator - Refer to the heater rating plate for the maximum and minimum inlet

pressure rating.

JOB SIZING

Proper job sizing is result of finding out as much information about the construction project as possible. Key information that must be determined are:

1. Cubic feet of structure
2. Design temperature/Desired temperature rise
3. Available fuel source
4. Available power source
5. Enclosure description

Page 15 of this guide will lead you through this process. Once this information is determined heating recommendations can be made.

FUEL AND POWER CONSUMPTION

Many factors (building tightness and actual weather conditions) can affect the fuel consumption on a heating project. Therefore, any cost calculation is just an estimate. Pages 24-25 of this guide provides a worksheet for estimating project costs.



Follow up and communication with the contractor throughout the heating season are extremely important to a successful sale and repeat business. Keeping good records on every job will improve knowledge and future success.

Direct Fired (Dual Fuel Series)



Model#	BTU	Fuel Type		Thermostat	Temp. Rise	Power	CFM	Ductable
		Propane	Nat. Gas					
 DG250	250,000	•		On/Off	170°	120V	2,766	Yes
 S405	400,000	•		On/Off	344°	120V	2,000	No
 DG400	400,000	•		On/Off	180°	120V	4,120	Yes
 1800B	750,000 450,000	• *		Hi/Lo/Off	385°	120V	4,200	Yes
 950H	950,000 650,000	• *		Hi/Lo/Off	250°	120V	7,000	Yes
 S1505B	1,500,000 850,000	•		Hi/Lo/Off	350°	120V	7,000	No
 2730C	2,000,000 600,000	• *		Hi/Lo	220°	240/480V	12,500	Yes
 3050	3,500,000 1,050,000	• *		Hi/Lo	200°	240/480V	16,000	Yes
 4210	5,000,000	• *		Hi/Lo	N/A	240/480V	27,500	Yes
4215	6,000,000	• *		Hi/Lo	N/A	240/480V	33,500	Yes
4220	7,000,000	• *		Hi/Lo	N/A	240/480V	40,100	Yes

*Liquid Propane Optional

Make-Up Air Heaters (Concealed Flame)

Model#	BTU	Fuel Type		Thermostat	Temp. Rise	Power	CFM	Ductable
		Propane	Nat. Gas					
 SURE FLAME SE410	400,000	•		On/Off	210°	120V	4,500	Yes
	 SURE FLAME S2200D	2,250,000 1,950,000 LP 1,650,000 NG	•		Hi/Lo/Off	390°	240/480V	12,000
 750NEF	750,000	•		Hi/Lo/Off	250°	120V	7,000	Yes

Direct Fired (Oil Series)

Model#	BTU	Fuel Type	Thermostat (optional)	Run Time (hrs.)	Power	CFM	Ductable
 DF400	400,000	*	On/Off	12.6	120V	2,500	No
 DF600	600,000	*	On/Off	8.3	120V	2,800	No

*#1, #2 diesel, kerosene, JP-8 or Jet A fuel

Infrared (Oil Series)

Model#	BTU	Fuel Type	Thermostat (optional)	Run Time (hrs.)	Power	Tank Capacity	Ductable
 HRF115	115,000	*	On/Off	13.4	120V	11.35 gal.	No

*#1, #2 diesel, kerosene, JP-8 or Jet A fuel

www.heatwagon.com

Visit our website for additional information . . .

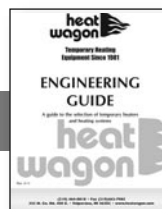

Indirect Fired (Gas Series)



Model#	BTU	Fuel Type Propane Nat. Gas	Temp. Rise	Power	CFM	Ductable
VG400	400,000	•	200°	120V	2,100	Yes



SURE FLAME

IX405	400,000	•	250°	120V	5,000	Yes
-------	---------	---	------	------	-------	-----



VG600A	600,000	•	120°	120V	7,063	Yes
--------	---------	---	------	------	-------	-----

SF US Pending



VG750	750,000	•	100°	240V-1	9,400	Yes
-------	---------	---	------	--------	-------	-----

Adaptors included

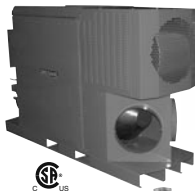

SURE FLAME

IX800	800,000	•	130°	240V-1/3	6,000 (13,600 Fan Rating)	Yes
-------	---------	---	------	----------	------------------------------	-----



VG1000	1,000,000	•	200°	240V-1	4,075	Yes
--------	-----------	---	------	--------	-------	-----



VG1100	1,000,000	•	110°	240V-1	11,200	Yes
--------	-----------	---	------	--------	--------	-----

Adaptors included











SURE FLAME

IX1500	1,500,000	•	170°	240/480V	8,300 (18,000 Fan Rating)	Yes
--------	-----------	---	------	----------	------------------------------	-----



Indirect Fired (Oil Series)

	Model#	BTU	Fuel Type Fuel Oil	Temp. Rise	Power	CFM	Ductable	Tank Size (gallons)
	HVF110	110,000	*	160°	120V	1,020	Yes	17
	HVF210	205,000	*	160°	120V	1,530	Yes	28
	HVF310	300,000	*	160°	120V	2,500	Yes	36
	HVF410	412,000 272,000	*	160°	120V	3,250	Yes	57
	VF400	400,000	*	200°	120V	2,100	Yes	75 (optional)
	VF600A	600,000	*	120°	120V	7,063	Yes	200 (optional)
	VF750	750,000	*	100°	240V-1	9,400	Yes	200 (optional)
	ID800	800,000	*	160°	240V-1, 3	13,600	Yes	117 (optional)
	VF1100	1,000,000	*	110°	240V-1	11,200	Yes	200 (optional)

Shown with optional 75 gallon tank

Shown with optional 200 gallon double-wall tank

Shown with optional 2-way duct splitter

*#1, #2 diesel, kerosene, JP-8 or Jet A fuel

OCTOBER TEMPERATURES				
STATE	CITY	NORMAL DAILY MEAN ° F	NORMAL DAILY MINIMUM ° F	* OUTDOOR DESIGN ° F
AK	ANCHORAGE	34.1	28.3	-23
CO	DENVER	51.0	35.9	-5
IA	DES MOINES	52.8	42.2	-10
ID	BOISE	52.8	41.3	3
IL	CHICAGO	52.1	42.1	-8
KY	LOUISVILLE	58.5	48.5	5
MA	BOSTON	54.1	46.4	6
MD	BALTIMORE	55.4	43.7	10
ME	PORTLAND	47.7	37.4	-6
MI	DETROIT	51.9	42.5	3
MN	MINNEAPOLIS	48.7	38.9	-16
MO	KANSAS CITY	56.8	45.9	2
MO	ST. LOUIS	58.3	48.2	2
MT	GREAT FALLS	45.5	33.0	-21
ND	FARGO	45.3	34.4	-23
NM	ALBUQUERQUE	57.3	43.8	12
NY	NEW YORK	57.7	50.9	11
NY	ROCHESTER	50.4	41.1	1
OH	COLUMBUS	54.7	44.0	0
PA	PITTSBURG	52.5	42.5	1
SD	SIOUX FALLS	48.0	34.8	-15
UT	SALT LAKE CITY	52.5	41.0	3
VA	RICHMOND	58.3	47.2	14
WA	SEATTLE	52.7	45.7	21
WV	CHARLESTON	55.1	43.1	7

Note: * For Permanent Heat Designs Use Outdoor Design

NOVEMBER TEMPERATURES				
STATE	CITY	NORMAL DAILY MEAN ° F	NORMAL DAILY MINIMUM ° F	* OUTDOOR DESIGN ° F
AK	ANCHORAGE	21.8	15.9	-23
CO	DENVER	37.5	23.5	-5
IA	DES MOINES	37.9	29.0	-10
ID	BOISE	39.9	32.4	3
IL	CHICAGO	39.3	31.6	-8
KY	LOUISVILLE	47.6	39.3	5
MA	BOSTON	44.9	37.9	6
MD	BALTIMORE	45.5	34.7	10
ME	PORTLAND	38.3	29.5	-6
MI	DETROIT	40.7	33.5	3
MN	MINNEAPOLIS	32.5	24.8	-16
MO	KANSAS CITY	42.7	33.4	2
MO	ST. LOUIS	45.3	36.7	2
MT	GREAT FALLS	32.3	22.5	-21
ND	FARGO	27.0	18.7	-23
NM	ALBUQUERQUE	44.4	31.6	12
NY	NEW YORK	47.6	41.6	11
NY	ROCHESTER	39.9	32.6	1
OH	COLUMBUS	43.7	34.9	0
PA	PITTSBURG	42.3	34.2	1
SD	SIOUX FALLS	31.3	20.7	-15
UT	SALT LAKE CITY	39.6	30.4	3
VA	RICHMOND	49.0	38.4	14
WA	SEATTLE	45.2	39.9	21
WV	CHARLESTON	45.9	35.3	7

Note: * For Permanent Heat Designs Use Outdoor Design

DECEMBER TEMPERATURES				
STATE	CITY	NORMAL DAILY MEAN ° F	NORMAL DAILY MINIMUM ° F	* OUTDOOR DESIGN ° F
AK	ANCHORAGE	17.5	11.4	-23
CO	DENVER	30.3	16.4	-5
IA	DES MOINES	24.9	16.7	-10
ID	BOISE	30.6	24.1	3
IL	CHICAGO	27.4	20.4	-8
KY	LOUISVILLE	37.6	29.9	5
MA	BOSTON	34.8	27.8	6
MD	BALTIMORE	36.7	27.3	10
ME	PORTLAND	27.6	29.5	-6
MI	DETROIT	29.6	23.4	3
MN	MINNEAPOLIS	18.7	10.9	-16
MO	KANSAS CITY	31.3	22.5	2
MO	ST. LOUIS	33.9	25.8	2
MT	GREAT FALLS	24.3	14.4	-21
ND	FARGO	12.5	4.2	-23
NM	ALBUQUERQUE	36.1	24.2	12
NY	NEW YORK	37.9	32.0	11
NY	ROCHESTER	29.4	22.7	1
OH	COLUMBUS	33.5	25.9	0
PA	PITTSBURG	32.5	25.3	1
SD	SIOUX FALLS	18.3	7.8	-15
UT	SALT LAKE CITY	30.2	22.4	3
VA	RICHMOND	40.4	31.1	14
WA	SEATTLE	40.7	35.9	21
WV	CHARLESTON	37.5	28.2	7

Note: * For Permanent Heat Designs Use Outdoor Design

JANUARY TEMPERATURES				
STATE	CITY	NORMAL DAILY MEAN ° F	NORMAL DAILY MINIMUM ° F	* OUTDOOR DESIGN ° F
AK	ANCHORAGE	15.8	9.3	-23
CO	DENVER	29.7	15.2	-5
IA	DES MOINES	20.4	11.7	-10
ID	BOISE	30.2	23.6	3
IL	CHICAGO	21.0	14.3	-8
KY	LOUISVILLE	33.0	24.9	5
MA	BOSTON	28.6	22.1	6
MD	BALTIMORE	32.3	23.5	10
ME	PORTLAND	20.8	12.5	-6
MI	DETROIT	22.9	17.8	3
MN	MINNEAPOLIS	11.8	4.3	-16
MO	KANSAS CITY	25.7	17.8	2
MO	ST. LOUIS	29.6	21.2	2
MT	GREAT FALLS	21.7	11.3	-21
ND	FARGO	6.8	-2.3	-23
NM	ALBUQUERQUE	35.7	23.8	12
NY	NEW YORK	31.2	26.5	11
NY	ROCHESTER	23.9	16.6	1
OH	COLUMBUS	28.3	20.3	0
PA	PITTSBURG	26.1	19.9	1
SD	SIOUX FALLS	14.0	2.9	-15
UT	SALT LAKE CITY	27.9	21.3	3
VA	RICHMOND	36.4	27.6	14
WA	SEATTLE	41.3	35.9	21
WV	CHARLESTON	33.4	24.2	7

Note: * For Permanent Heat Designs Use Outdoor Design

FEBRUARY TEMPERATURES				
STATE	CITY	NORMAL DAILY MEAN ° F	NORMAL DAILY MINIMUM ° F	* OUTDOOR DESIGN ° F
AK	ANCHORAGE	18.7	11.7	-23
CO	DENVER	31.7	19.1	-5
IA	DES MOINES	26.6	17.8	-10
ID	BOISE	36.7	28.8	3
IL	CHICAGO	27.0	19.2	-8
KY	LOUISVILLE	37.6	28.5	5
MA	BOSTON	31.5	24.2	6
MD	BALTIMORE	35.5	26.1	10
ME	PORTLAND	24.8	15.6	-6
MI	DETROIT	27.2	20.0	3
MN	MINNEAPOLIS	20.1	11.8	-16
MO	KANSAS CITY	33.0	23.3	2
MO	ST. LOUIS	35.4	26.5	2
MT	GREAT FALLS	26.4	15.1	-21
ND	FARGO	14.1	5.4	-23
NM	ALBUQUERQUE	41.4	28.2	12
NY	NEW YORK	34.8	28.3	11
NY	ROCHESTER	25.3	17.3	1
OH	COLUMBUS	32.0	23.5	0
PA	PITTSBURG	30.5	22.3	1
SD	SIOUX FALLS	20.8	10.1	-15
UT	SALT LAKE CITY	34.5	25.5	3
VA	RICHMOND	39.5	29.7	14
WA	SEATTLE	43.3	37.2	21
WV	CHARLESTON	36.9	26.7	7

Note: * For Permanent Heat Designs Use Outdoor Design

CHART 6

Heat Requirement Estimator
 Building Condition vs. BTU/CUBIC FOOT

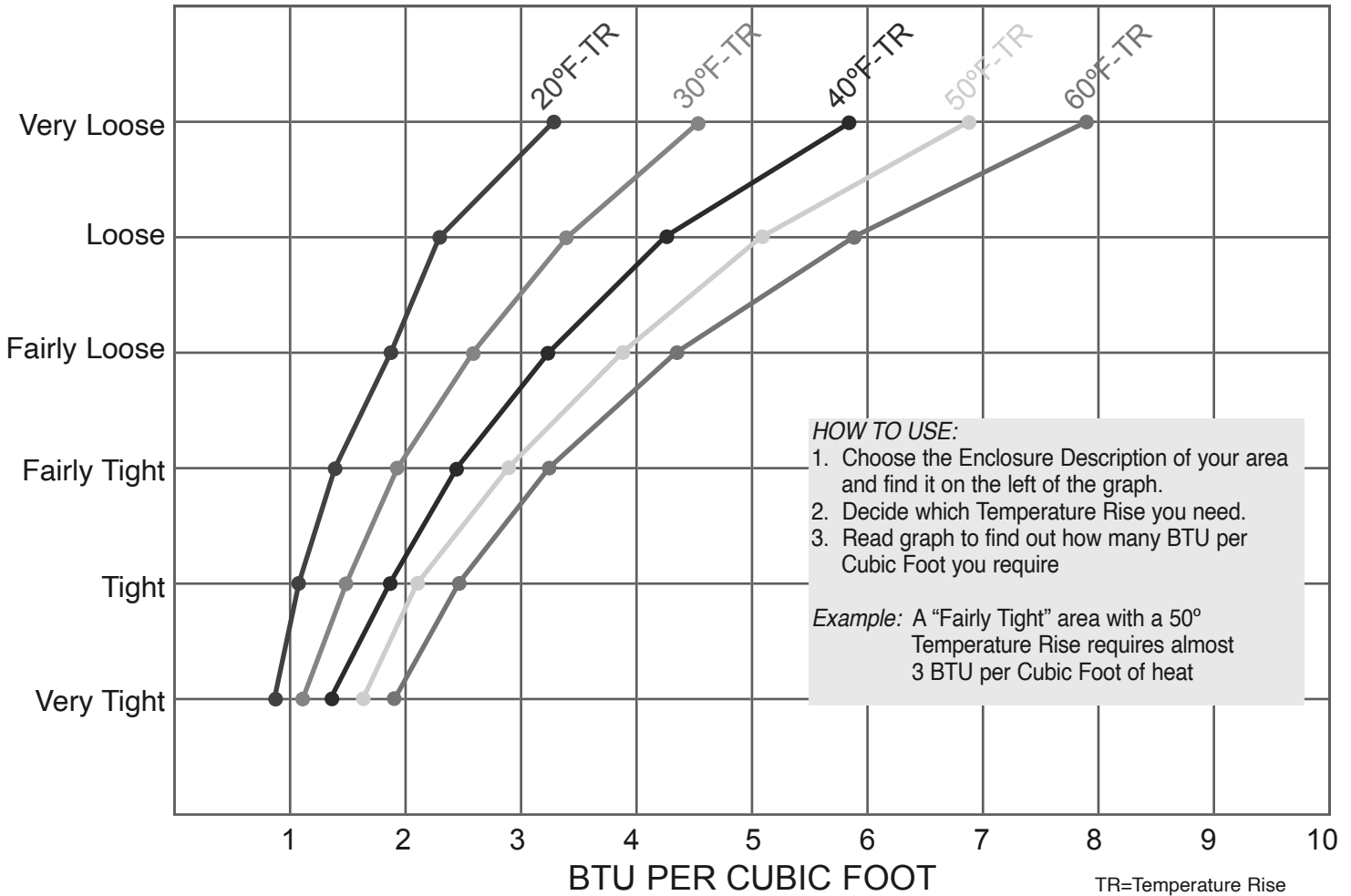

ENCLOSURE DESCRIPTION

The heat requirement calculator provides general guidelines and is based upon a temperature rise from 20° - 60°F. On-the-job-site experience is a factor in final estimates. A job log is helpful for comparison of the estimates and final requirements, and further facilitates similar structure estimates.

Heating requirements are governed by the type of temporary enclosure that exists. Less heat is required for a tight enclosure.

Additional heating capacity is necessary to reach the desired temperature of a frozen space. The amount of frost in a structure determines the additional heating capacity, which can be terminated when frost and water vapor are no longer factors.

VERY TIGHT

Structural enclosure - windows, doors, and elevators installed, walls exist (not dry-walled) -no partitioning*

TIGHT

Structural enclosure - windows, doors, and elevators installed, walls exist (not dry-walled) -medium partitioning*

FAIRLY TIGHT

Structural enclosure - tight roof and completed walls without insulation, window and door openings enclosed with canvas or plastic - medium to heavy partitioning*

FAIRLY LOOSE

Structural enclosure - tight roof and nearly completed walls; door, window and other openings covered with plastic or canvas - medium partitioning*

LOOSE

Structural enclosure - tight roof and nearly completed walls; door, window and other openings covered with plastic or canvas - heavy partitioning*

VERY LOOSE

Structural enclosure - tight roof, sheet plastic or canvas walls - space is clear of significant partitioning*

**When heat is supplied from the beginning of the heating season, or if a space is well heated, partitioning isn't a vital factor.*

CHART 7

NATURAL GAS QUICK REFERENCE HOSE CHART														
Hose Length in Feet	400,000		750,000		1 Million		BTU		2 Million		3 Million		4 Million	
	2PSI	5PSI	2PSI	5PSI	2PSI	5PSI	2PSI	5PSI	2PSI	5PSI	2PSI	5PSI	2PSI	5PSI
10	3/4	-	3/4	-	3/4	3/4	3/4	3/4	1-1/4	3/4	1-1/4	3/4	1-1/4	1-1/4
25	3/4	-	3/4	-	3/4	3/4	3/4	3/4	1-1/4	1-1/4	1-1/4	1-1/4	1-1/4	1-1/4
35	3/4	-	3/4	-	3/4	3/4	3/4	3/4	1-1/4	1-1/4	1-1/4	1-1/4	-	1-1/4
50	3/4	-	3/4	-	1	3/4	1-1/4	1	1-1/4	1-1/4	-	1-1/4	-	1-1/4
75	3/4	-	3/4	-	1-1/4	3/4	1-1/4	1	-	1-1/4	-	1-1/4	-	-
100	3/4	-	1	3/4	1-1/4	3/4	1-1/4	1-1/4	-	1-1/4	-	1-1/4	-	-
125	3/4	-	1-1/4	3/4	1-1/4	3/4	1-1/4	1-1/4	-	1-1/4	-	-	-	-
150	3/4	-	1-1/4	3/4	1-1/4	3/4	1-1/4	1-1/4	-	1-1/4	-	-	-	-
175	3/4	-	1-1/4	3/4	1-1/4	3/4	-	1-1/4	-	1-1/4	-	-	-	-
200	3/4	-	1-1/4	3/4	1-1/4	3/4	-	1-1/4	-	1-1/4	-	-	-	-
225	3/4	-	1-1/4	3/4	1-1/4	3/4	-	1-1/4	-	1-1/4	-	-	-	-

Consult figure for applications outside these pressures and hose sizes

CHART 7-1

VAPOR PROPANE QUICK REFERENCE HOSE CHART														
Hose Length in Feet	400,000		750,000		1 Million		BTU		2 Million		3 Million		4 Million	
	1/2PSI	10PSI	1/2PSI	10PSI	1/2PSI	10PSI	1/2PSI	10PSI	1/2PSI	10PSI	1/2PSI	10PSI	1/2PSI	10PSI
10	3/4	3/4	3/4	3/4	1-1/4	3/4	1-1/4	3/4	-	3/4	-	3/4	-	3/4
25	3/4	3/4	1-1/4	3/4	1-1/4	3/4	1-1/4	3/4	-	3/4	-	3/4	-	3/4
35	1-1/4	3/4	1-1/4	3/4	1-1/4	3/4	1-1/4	3/4	-	3/4	-	3/4	-	1
50	1-1/4	3/4	1-1/4	3/4	-	3/4	1-1/4	3/4	-	3/4	-	3/4	-	1
75	1-1/4	3/4	1-1/4	3/4	-	3/4	-	3/4	-	3/4	-	1	-	1
100	1-1/4	3/4	-	3/4	-	3/4	-	3/4	-	3/4	-	1	-	1
125	1-1/4	3/4	-	3/4	-	3/4	-	3/4	-	3/4	-	1	-	1-1/4
150	1-1/4	3/4	-	3/4	-	3/4	-	1-1/4	-	3/4	-	1	-	1-1/4
175	1-1/4	3/4	-	3/4	-	3/4	-	1-1/4	-	3/4	-	1	-	1-1/4
200	1-1/4	3/4	-	3/4	-	3/4	-	1-1/4	-	3/4	-	1	-	1-1/4
225	1-1/4	3/4	-	3/4	-	3/4	-	1-1/4	-	3/4	-	1-1/4	-	1-1/4

Consult figure for applications outside these pressures and hose sizes

CHART 8

VAPORIZATION RATES IN BTUH @ 0 DEG. F							
TANK SIZE	NUMBER OF TANKS MANIFOLDED	PERCENTAGE OF TANK FILLED					
		10%	20%	30%	40%	50%	60%
250	1	126,900	169,200	197,400	225,600	253,800	282,000
	2	279,180	372,240	434,280	496,320	558,360	620,400
	3	486,027	648,036	756,042	864,048	972,054	1,080,060
325	1	160,650	214,200	249,900	285,600	321,300	357,000
	2	353,430	471,240	549,780	628,320	706,860	785,400
	3	615,289	820,386	957,117	1,093,848	1,230,579	1,368,842
500	1	198,135	264,180	308,212	352,240	396,270	440,300
	2	435,897	581,196	687,066	774,928	871,794	968,660
	3	758,857	1,011,809	1,180,451	1,349,079	1,517,714	1,686,349
850	1	304,425	405,900	473,550	541,200	608,850	676,500
	2	669,735	892,980	1,041,810	1,190,640	1,339,470	1,488,300
	3	1,165,947	1,554,597	1,813,696	2,072,796	2,331,895	2,590,995
1000	1	354,240	472,320	551,040	629,760	708,480	787,200
	2	779,328	1,039,104	1,212,288	1,385,472	1,558,656	1,731,840
	3	1,356,739	1,808,985	2,110,483	2,411,980	2,713,478	3,014,976

NOTE: USE FOLLOWING MULTIPLIERS FOR OTHER AIR TEMPERATURES

- For -10°F multiply x 0.50
- For +10°F multiply x 1.5
- For +20°F multiply x 2.0
- For +40°F multiply x 3.0
- For +50°F multiply x 3.5
- For +60°F multiply x 4.0

CHART 9 TANK PRESSURES

Temp. (F)	Approx. Pressure (PSIG)-Propane
-40	3.6
-30	8.0
-20	13.5
-10	20.0
0	28.0
10	37.0
20	47.0
30	58.0
40	72.0

NATURAL GAS

CHART 10 Capacity of pipe at less than 1.0 - psig inlet pressure in cubic feet of gas per hour

IPS, nom., in.	EQUIVALENT PIPE LENGTH, FT.									
	50	100	150	200	250	300	400	500	1000	1500
1	244	173	141	122	109	99	86	77	54	44
1-1/4	537	380	310	268	240	219	189	169	119	97
1-1/2	832	588	480	416	372	339	294	263	185	151
2	1680	1188	970	840	751	685	594	531	375	306
2-1/2	2754	1952	1591	1379	1232	1123	974	869	617	504
3	5018	3549	2896	2509	2244	2047	1774	1587	1121	915
4	10510	7410	6020	5170	4640	4480	3660	3340	2360	1910
5	19110	13480	10960	9410	8440	8150	6660	6070	4290	3480
6	31140	21960	17860	15320	13760	13280	10860	9890	7000	5670
8	63310	44740	36380	31220	28020	27040	22120	20150	14250	11550
10	113020	79720	64830	55630	49940	48180	39420	35920	25400	20580
12	177450	125180	101790	87350	78400	75650	61900	56400	39890	32320

CHART 10-1 Capacity of pipe at 1.0 - psig inlet pressure in cubic feet of gas per hour
(Based on a pressure drop of 0.1 psig and 0.6 sp gr gas in schedule - 40 pipe)

IPS, nom., in.	EQUIVALENT PIPE LENGTH, FT.								
	50	100	150	200	300	400	500	1000	1500
1	740	520	430	370	300	260	230	170	130
1-1/4	1540	1090	890	760	630	540	490	350	280
1-1/2	2330	1650	1350	1160	960	830	740	530	420
2	4550	3210	2640	2260	1870	1610	1440	1040	830
2-1/2	7330	5180	4250	3650	3020	2600	2320	1690	1340
3	13100	9260	7600	6520	5400	4660	4160	3020	2400
3-1/2	19320	13650	11210	9610	7960	6870	6130	4450	3540
4	26980	19070	15650	13430	11120	9590	8560	6220	4940
5	49340	34870	28620	24550	20330	17550	15660	11370	9030
6	80560	56940	46740	40909	33210	28650	25580	18570	14760

CHART 10-2 Capacity of pipe at 2.0 - psig inlet pressure in cubic feet of gas per hour
(Based on a pressure drop of 0.2 psig and 0.6 sp gr gas in schedule - 40 pipe)

IPS, nom., in.	EQUIVALENT PIPE LENGTH, FT.									
	50	100	150	200	300	400	500	1000	1500	2000
1	1080	760	620	540	440	380	340	240	190	170
1-1/4	2250	1590	1300	1120	910	790	710	500	410	350
1-1/2	3410	2410	1970	1700	1390	1200	1070	760	620	530
2	6640	4700	3840	3310	2700	2350	2090	1480	1210	1040
2-1/2	10700	7580	6190	5340	4360	3790	3380	2390	1960	1690
3	19120	13540	11060	9540	7790	6770	6040	4280	3500	3020
3-1/2	28200	19970	16310	14070	11490	9980	8900	6310	5160	4450
4	39380	27890	22780	19650	16040	13940	12440	8810	7210	6220
5	72010	50990	41650	35930	29300	25490	22740	16120	13180	11370
6	117580	83270	68010	58670	47900	41630	37140	26320	21520	18570

CHART 10-3 Capacity of pipe at 5.0 - psig inlet pressure in cubic feet of gas per hour
(Based on a pressure drop of 0.5 psig and 0.6 sp gr gas in schedule - 40 pipe)

IPS, nom., in.	EQUIVALENT PIPE LENGTH, FT.								
	50	100	150	200	300	400	500	1000	1500
1	1860	1320	1070	930	760	660	590	410	340
1-1/4	3870	2740	2240	1930	1580	1370	1220	860	700
1-1/2	5860	4140	3390	2930	2390	2080	1850	1310	1060
2	11420	8070	6600	5710	4660	4050	3610	2550	2080
2-1/2	18400	13010	10640	9200	7510	6530	5820	4110	3350
3	32860	23240	19000	16430	13410	11660	10390	7340	5990
3-1/2	48480	34280	28030	24240	19780	17200	15330	10820	8840
4	67700	47880	39140	33850	27630	24020	21410	15120	12340
5	123790	87540	71570	61890	50530	43920	39160	27640	22570
6	202138	142950	116870	101060	82500	71720	63940	45140	36860

CHART 10-4 Capacity of pipe at 10.0 - psig inlet pressure in cubic feet of gas per hour
(Based on a pressure drop of 1.0 psig and 0.6 sp gr gas in schedule - 40 pipe)

IPS, nom., in.	EQUIVALENT PIPE LENGTH, FT.									
	50	100	150	200	300	400	500	1000	1500	2000
1	2930	2070	1690	1470	1190	1030	920	650	530	460
1-1/4	6090	4330	3520	3050	2490	2150	1920	1360	1110	960
1-1/2	9210	6530	5330	4620	3760	3260	2910	2060	1680	1460
2	17940	12720	10380	9000	7330	6360	5680	4020	3280	2840
2-1/2	28920	20500	16730	14510	11820	10250	9150	6480	5290	4580
3	51650	36610	29880	25920	21110	18300	16340	11570	9450	8190
3-1/2	76180	53990	44070	38240	31140	26990	24110	17070	13950	12080
4	106400	75410	61550	53410	43500	37700	33670	23850	19480	16870
5	194540	137890	112550	97650	79540	68940	61570	43600	35620	30860
6	317650	225150	183770	159450	129870	112560	100540	71200	58160	50390

CHART 10-5 Capacity of pipe at 20.0 - psig inlet pressure in cubic feet of gas per hour
(Based on a pressure drop of 2.0 psig and 0.6 sp gr gas in schedule - 40 pipe)

IPS, nom., in.	EQUIVALENT PIPE LENGTH, FT.									
	50	100	150	200	300	400	500	1000	1500	2000
1	4900	3470	2810	2450	2000	1730	1550	1070	890	770
1-1/4	10190	7210	5840	5090	4160	3600	3220	2230	1860	1610
1-1/2	15420	10900	8830	7710	6290	5450	4870	3370	2810	2440
2	30030	21230	17190	15010	12260	10610	9490	6570	5480	4760
2-1/2	48390	34220	27710	24190	19750	17110	15290	10590	8830	7670
3	86420	61110	49490	43190	35280	30550	27310	18910	15770	13690
3-1/2	127480	90130	73000	63710	52040	45070	40280	27900	23270	20200
4	178040	125880	101950	88980	72680	62940	56260	38960	32500	28210
5	325530	230170	186410	162700	132890	115080	102870	71240	59420	51590
6	531530	375820	304370	265660	216990	187910	167980	116330	97030	84240



CHART 11

LIQUID PROPANE FLOW - GPH	LENGTH OF HOSE OR IRON PIPE (FEET)															
	1/4"		3/8"		1/2"		3/4"		1"		1 1/4"		1 1/2"		2"	
	HOSE SCHED 40	PIPE SCHED 80	HOSE SCHED 40	PIPE SCHED 80	HOSE SCHED 40	PIPE SCHED 80	HOSE SCHED 40	PIPE SCHED 80	HOSE SCHED 40	PIPE SCHED 80	HOSE SCHED 40	PIPE SCHED 80	HOSE SCHED 40	PIPE SCHED 80	HOSE SCHED 40	PIPE SCHED 80
10	729	416														
15	324	185														
20	182	104	825	521												
40	46	26	205	129	745	504										
60	20	11	92	58	331	224										
80	11	6	51	32	187	127	735	537								
100	7	4	33	21	119	81	470	343								
120			23	15	83	56	326	238								
140			15	9	61	41	240	175	813	618						
160			13	8	47	32	184	134	623	473						
180					37	25	145	106	491	373						
200					30	20	118	86	399	303						
240					21	14	81	59	227	211						
280					15	10	60	44	204	155						
300					13	9	52	38	177	135	785	623				
350							38	28	130	99	578	459				
400							30	22	99	75	433	344	930	794		
500							19	14	64	49	283	225	627	508		
600									44	33	197	156	435	352		
700									32	24	144	114	320	259		
800									25	19	110	87	245	198	965	795
900									19	14	87	69	194	157	764	630
1000									16	12	71	56	157	127	618	509
1500											31	25	70	57	275	227
2000											18	14	39	32	154	127
3000											8	6	17	14	69	57
4000													10	8	39	32
5000															25	21
10000															6	5

TO USE CHART:

1. Having determined the required flow at point of use, locate this flow in the left hand column. If this falls between two figures, use the larger of the two.
2. Determine total length of piping required from source to point of use. Locate length in the center of this chart.
3. Read across chart from left (required flow) to right to find the total length which is equal to or exceeds the distance from the source to use.
4. From this point read up to find the correct size of pipe required

CHART 12

PIPE & TUBING SIZING - HIGH PRESSURE PROPANE SIZING BETWEEN FIRST AND SECOND STAGE REGULATOR

PIPE OR TUBING LENGTH	TUBING SIZE, O.D., TYPE L						NOMINAL PIPE SIZE, SCHEDULE 40									
	3/8	1/2	5/8	3/4	7/8	1-1/8	1/2	3/4	1	1-1/4	1-1/2	2	2-1/2	3	4	
10	730	1700	3200	2300	8300	17000	3200	7500	12800	24000	40000	88000	133000	237500	489000	
20	500	1100	2200	3700	5800	12000	2200	4200	8800	18000	33000	61000	92500	165500	341000	
30	400	920	2000	2900	4700	9800	1800	4000	7200	14000	26000	49000	76500	136500	281000	
40	370	850	1700	2700	4100	8500	1600	3700	6800	13500	24000	46000	71000	127000	262000	
50	330	770	1500	2400	3700	7600	1500	3400	6300	12600	22500	43000	65000	116000	240000	
60	300	700	1300	2200	3300	7000	1300	3100	5600	12000	21700	40000	61000	109000	224000	
80	260	610	1200	1900	2900	6000	1200	2600	4900	10000	18000	34000	52000	93000	192000	
100	220	540	1000	1700	2600	5400	1000	2300	4300	9000	15000	31000	45500	81500	168000	
125	200	490	900	1400	2300	4800	900	2100	4000	7900	13500	28000	41500	74000	152500	
150	190	430	830	1300	2100	4400	830	1900	3600	7200	12600	25000	37000	66500	137000	
175	170	400	780	1200	1900	4000	770	1700	3300	6700	11400	23500	34500	61500	127000	
200	160	380	730	1100	1800	3800	720	1500	3100	6200	10600	22000	32000	57500	119000	

To convert to capacities at 5 psig settings - Multiply by 0.879
 To convert to capacities at 15 psig settings - Multiply by 1.130
 To convert to capacities at 20 psig settings - Multiply by 1.185

To convert to capacities at 30 psig settings - Multiply by 1.345
 To convert to capacities at 40 psig settings - Multiply by 1.488
 To convert to capacities at 50 psig settings - Multiply by 1.618

CHART 13









SECOND STAGE SERVICE REGULATOR (11SV08, 40SV06) FLOW RATE IN CFH								
PRESSURE (PSI)	ORIFICE SIZE							
	1/8"	1/8"X3/16"	3/16"	1/4"	5/16"	3/8"	1/2"	1/2"X9/16"
1				190	270	280	550	575
2		190	220	300	430	450	820	860
3	160	215	300	380	550	560	1030	1080
5	230	280	390	550	710	740	1230	1310
10	370	390	600	820	1050	1130	1650	1680
15	460	525	800	1070	1340	1460		
20	610	700	1000	1320	1630	1800		
30	800	890	1340	1750	1950			
40	1030	1150	1750	2050				
50	1200	1300	2010	2300				
60	1310	1425	2250	2500				
80	1900	2000	2580					
100	2200	2275	2700					
125	2200	2275	2900					

NOTE: USE 1050 BTU PER CFH FOR NATURAL GAS
USE 2476 BTU PER CFH FOR PROPANE

11SV08 REGULATOR COMES STANDARD WITH 1/2" ORIFICE
40SV06 REGULATOR COMES STANDARD WITH 1/4" ORIFICE

CHART 14 - Relocated to back page

Electric Heaters

Model#	BTU	KW	Built-In		Power	CFM	Ductable
			Thermostat	Amps			
 P1500	5,100	1.5	Yes	15	120V	120	No
<i>Comes with plug and cord</i>							
 P300	10,200	3	Yes	12.5	208-240V-1	205	No
<i>Comes with plug and cord</i>							
 P600	20,500	6	Yes	25	208-240V-1	250	No
<i>Comes with plug and cord</i>							
 P900	30,700	9	Yes	38	208-240V-1	350	No
<i>Comes with plug and cord</i>							
 P1800-1	65,000/41,000	18/12	Yes	75/50	208-240V-1	590	No
 P1800-3	65,000/41,000	18/12	Yes	50/34	208-240V-3	590	No
 P1800D	65,000/41,000	18/12	Yes	50/34	208-240V-3	950	Yes
 P4000	136,500 109,200 54,600	40 32 16	Yes Yes Yes	50 40 20	480V 480V 480V	1,800 1,800 1,800	Yes Yes Yes
 P6000	204,700 163,800 81,900	60 48 24	Yes Yes Yes	75 60 30	480V 480V 480V	1,800 1,800 1,800	Yes Yes Yes

Rated 100°F Temp Rise @ 0°F Max

TOTAL GAS LOAD

When determining hose and piping requirements, add all heaters flow requirements on a system for total gas load. In the following Figure use the total gas load, at the available pressure at the source, to determine hose or pipe size.

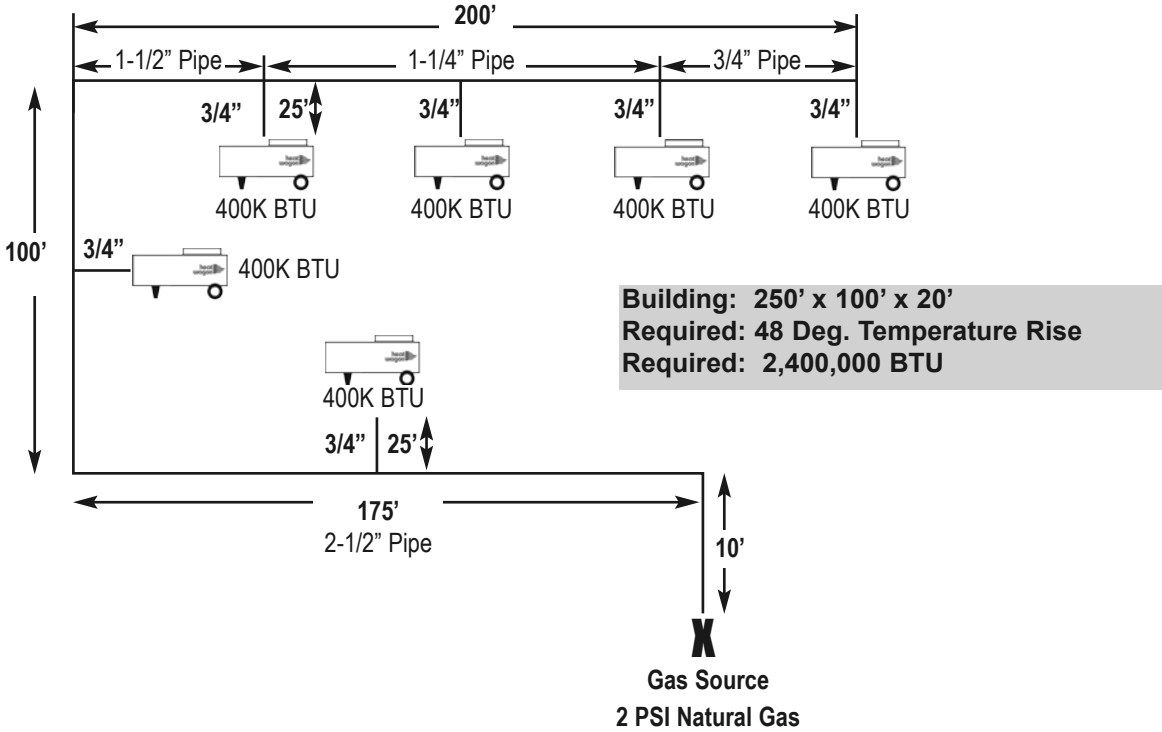

BULK TANK PLACEMENT

When using propane as a fuel and particularly as a liquid, the tanks should be positioned as shown. This should reduce oil in propane entering the heater and pouring components. An additional safeguard called a drip leg can be made to place in the heater pipe train.

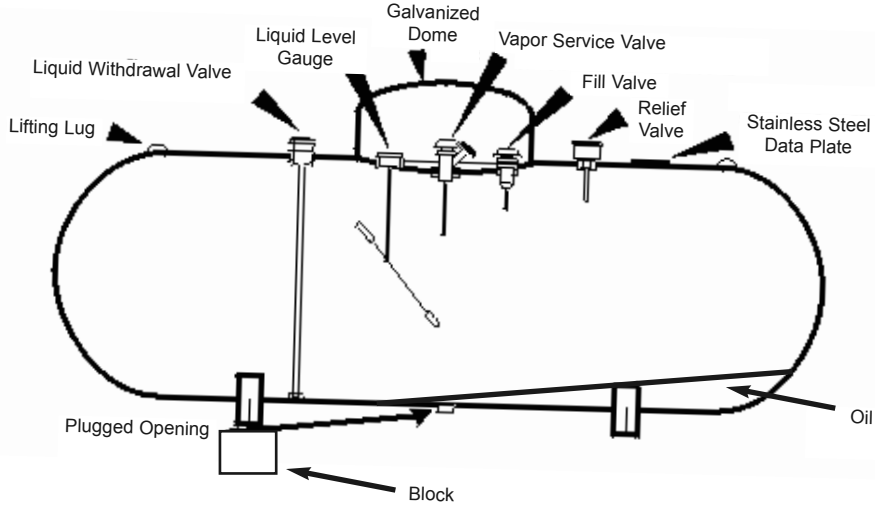

CHART 15

NATURAL GAS CONSUMPTION					
	THERMS PER HOUR		THERMS/24 HR PERIOD		
	HIGH FIRE	LOW FIRE	HIGH FIRE	LOW FIRE	
DG250	2.6	-	62	-	
DG400	4	-	97	-	
SE405	4	-	96	-	
S405	4	-	96	-	
1800B	7.5	3.4	180	82	
950H	9.5	4	228	96	
1200DF	12	VAR	288	VAR	
S1505B	15	8	360	192	
S2200	22	9.5	528	228	
2730	20	5	480	120	
3050	35	15	840	360	
VG175	1.75	-	42	-	
VG400	4	-	96	-	
VG500	5	-	120	-	
VG700	7	-	168	-	
VG1000	10	-	240	-	

NOTE: 100,000 BTU PER THERM
NOTE: 1 THERM = 100 CUBIC FT

CHART 16

PROPANE FUEL CONSUMPTION					
	GALLONS PER HOUR		GALLONS/24 HR PERIOD		
	HIGH FIRE	LOW FIRE	HIGH FIRE	LOW FIRE	
DG250	2.6	-	62	-	
DG400	4.3	-	103	-	
SE405	4.4	-	105.6	-	
S405	4.4	-	105.6	-	
1800B	8.3	3.76	198	89.7	
950H	10.5	4.4	252	105.6	
1200DF	13.2	VAR	316.8	VAR	
S1505B	16.5	8.8	395	211.2	
S2200	24.2	10.45	580.8	250.8	
2730	22	5.5	528	132	
3050	38.5	16.5	924	396	
VG175	1.9	-	45.6	-	
VG400	4.4	-	105.6	-	
VG500	5.5	-	132	-	
VG700	7.7	-	184.8	-	
VG1000	11	-	264	-	

NOTE: PROPANE 91,960 BTU PER GALLON
NOTE: 1.1 GAL PER HOUR PER 100,000 BTU
NOTE: LBS. PER GALLON - 4.24
NOTE: BTU PER LB. - 21,591

NOTE: KW = 3411 BTU



TEMPORARY HEATING ESTIMATING WORK SHEET SINGLE FLOOR APPLICATION

Cubic Feet _____ Enclosure (page 13) _____
 Outdoor Temp _____ °F BTU/Cubic Foot _____
 Indoor Temp _____ °F Cubic Feet x BTU/Cubic Ft. _____ BTU
 Temperature Rise _____ °F Cubic Feet ÷ 60 = _____ CFM

Fuel:

Nat Gas _____ w.c. or psi Pressure @ Source
Inches wc/psi

Propane _____ Pressure @ Source

Fuel Oil _____ Grade Power Cable _____

Distance Heat From Source: _____

Electric Power: Phase _____ Volt _____

Distance Power To Heater: _____

Recommended Specs

Qty.	Model	BTUH	Power	Hose/Pipe Dia.	Power Cable Size	Tank Size	
						V.P. (gal)	L.P. (gal)
_____	_____	_____	_____	_____	_____	_____	_____
_____	_____	_____	_____	_____	_____	_____	_____
_____	_____	_____	_____	_____	_____	_____	_____
_____	_____	_____	_____	_____	_____	_____	_____
_____	_____	_____	_____	_____	_____	_____	_____
_____	_____	_____	_____	_____	_____	_____	_____

FUEL CONSUMPTION

Model _____

GPM or CFH _____ (CFH x 100,000 = THERM)

Fuel Cost per GPM/THERM _____

Rental Period (in days) _____

Maximum fuel use per day
in GPM or THERMS (page 21) _____

Max. fuel use per rental period _____

Estimated Fuel Cost _____

Note: Most contractors experience less than 60% of maximum fuel consumption

POWER CONSUMPTION

*KWH/Day (page 24) _____

KWH in rental period _____

Cost per KWH _____

Estimated Power Cost _____

Recommend hose or pipe diameter _____

Recommend power cable size _____

Recommend bulk tank for vapor propane _____

Recommend bulk tank for liquid propane _____

Page 22

**Assuming 24 hour/day operation*

SUMMARY OF COSTS

Heater purchase or rental _____

Accessory purchase or rental _____

Estimated fuel cost _____

Estimated power cost _____

TOTAL

CHART 14

MINIMUM SUPPLY VOLTAGES						
	HP	KW	NAME PLATE AMPS	120V NOMINAL	240V NOMINAL	480V NOMIAL
SE405	3/4	1	8	105		
S405	1/4	2.9	12	105		
1800B	1	1.13	9.4	105		
750EF	1.5	1.8	15	105		
950H	1.5	1.8	15	105		
1200DF	5	17.5	27.6		208	
1500-1505	1	5	20	105		
S1505B	1	1.13	9.4	105		
S2000-S2200	5	16.5/9.9	20		208	440
2730C 1 PHASE	3	11.5	30		208	
2730C 3 PHASE	3	6.5	15		208	
2730C 3 PHASE	3	5.9	10			440
3050 1 PHASE	5	16.5	30		208	
3050 3 PHASE	5	10.5	20		208	
3050 3 PHASE	5	10.6	15			440
VG175	0.6	1.2	10	105		
VF400	0.871	3.7	10	105		
VG400	0.871	3.7	10	105		
VG500	3.0	2.3	11		208	
VG600A	1	1.5	12			
VG750	3	3.8	19.5		208	
VF1100	4	4.8	19		208	
VF1000	5	4.3	20		208	
VG1000	5	4.3	20		208	
P1500	N/A			105		
P300	N/A	3			208	
P600	1/10	6			208	
P900 1 PHASE	1/10	9	38		208	
P1800 1 PHASE	1/10	18/12	75/50		208	
P1800 3 PHASE	1/10	18/12	50/34		208	
P4000 3 PHASE	1/3	40/32/16	50			440
P6000 3 PHASE	1/3	60/48/24	75			440

Wire Size Resistance Chart		
#4	0.000308	Resistance per Foot
#6	0.000403	Resistance per Foot
#8	0.000641	Resistance per Foot
#10	0.00102	Resistance per Foot
#12	0.00162	Resistance per Foot
#14	0.00258	Resistance per Foot
#16	0.00409	Resistance per Foot
#18	0.00651	Resistance per Foot

* These voltages are a minimum. Cold weather can also reduce the amount of voltage. If you are close to these minimums, you need to increase wire size or shorten length of cord. Be aware of what power is at source.

To determine voltage drop, the formula is
 $\text{amps} \times \text{resistance} = \text{voltage drop}$

Example: 2730C 1 phase 30 amp
 Minimum Voltage Required=208V
 150 ft x 18 gauge wire (.00651) = .9765
 30 amps x .9765 = 29.29 voltage drop
 220v (at source) - 29.29 = 190.71volts
 Conclusion: Heater will not run, wire too small or cord too long

Options to correct the situation

- Increase gauge of wire
 Try 14 gauge wire
 150 ft. x 14 gauge wire (.00258) = .3870
 30 amps x .3870 = 11.61 voltage drop
 220v - 11.61 = 208.39 volts
 Conclusion: Heater will run, although still might be a problem because of cold weather conditions

Options to correct the situation

- Reduce cord length
 Try 50 feet
 50 ft. x 18 gauge wire (.00651) = .3255
 30 amps x .3255 = 9.765 voltage drop
 220v - 9.765 = 210.24 volts
 Conclusion: Heater will run

Regulators

Model 40SV06



SECOND STAGE GAS REGULATOR (FOR NATURAL GAS AND VAPOR PROPANE)

- 1/4" ORIFICE
- INLET 3/4" FNPT, OUTLET 1" FNPT
- MAX INCOMING GAS PRESSURE - 60 psi

OUTLET PRESSURE

- FACTORY SETTING, 11.0" WC (WATER COLUMN)
- ADJUSTABLE 9" TO 14" WC

NOTE: 1 psi = 2.8" WC

INCOMING PRESSURE, PSI, (NATURAL GAS)	FLOW RATE (EXPRESSED AS BTU/HR CAPABILITY)
1	190,000
3	380,000
5	550,000
10	820,000
20	1,320,000
40	2,050,000
60	2,500,000

FOR VAPOR PROPANE USE 2.35 MULTIPLIER FACTOR

Model 11SV08



SECOND STAGE GAS REGULATOR (FOR NATURAL GAS AND VAPOR PROPANE)

- 1/2" ORIFICE
- INLET AND OUTLET, 1.25" FNPT
- MAX INCOMING GAS PRESSURE - 10 psi

OUTLET PRESSURE

- FACTORY SETTING, 11.0" WC (WATER COLUMN)
- ADJUSTABLE 9" TO 14" WC

NOTE: 1 psi = 2.8" WC

INCOMING PRESSURE, PSI, (NATURAL GAS)	FLOW RATE (EXPRESSED AS BTU/HR CAPABILITY)
1	680,000
2	1,020,000
3	1,200,000
5	1,490,000
10	1,800,000

FOR VAPOR PROPANE USE 2.35 MULTIPLIER FACTOR

Model VF1100SC

Indirect Fired Self-Contained Fuel Oil Heater



- More BTU's
- More CFM
- More Static Pressure
- More Fuel Efficient
- More Run Time



- Reliable Riello burner
- Remote thermostat with 50' cord
- Ductable up to 150 ft.
- Convenient duct storage
- 200 gallon fuel cell with immersion heater (Double wall construction)
- Over 30 hours operating time



Heater Only

SPECIFICATIONS

Heater

1,000,000 BTU/Hr
#1 or #2 Diesel, Kerosene
7.16 GPH Fuel Consumption
240 Volts 20 amp circuit
11,183 CFM, 1.2" S.P.
Standard On/Off Thermostat
120°F @ 0°F Ambient Temp Rise
85% Rated Efficiency
2 - 24" Duct Size
CSA Approved Pending
Riello 40 F22 Burner

Generator Set

Multiquip Model DA7000 SSA
7kW Max Power
6kW Continuous Power
3600 RPM, 60 Hz AC
Kubota 2 Cylinder Engine
Liquid Cooled
Hour Meter

Trailer

DOT Approved
2 x 3,500 Lbs. Dual Axle
4 x 15" Tires
7 Pin Trailer Plug
Electric Brakes
Safety Chains, 2" Trailer Ball
Duct Storage Cabinet
200 Gallon Fuel Cell with 500 Watt
Immersion Heater
Front Screw Jack
18'L x 5'-8"W x 9'D
3,740 Lbs. (Empty)